

**HUSS**<sup>®</sup>  
PARK ATTRACTIONS

# BOOSTER REVOLUTION



THE ULTIMATE G-FORCE ENCOUNTER

# BOOSTER REVOLUTION

## *THE ULTIMATE G-FORCE ENCOUNTER*

The Booster is an **extreme thrill ride** attraction, part of the **HUSS® Signature Rides Collection** and a true **HUSS® Original**.

The completely redesigned attraction guarantees the fast and furious ride experience that thrill-seekers are looking for.

The innovative HUSS® Operator Centre Stage, multi-media elements and special effects make this staged show ride a highlight in any attraction landscape.

The decagonal main disc, with a diameter of less than 20 metres, carries five cross-shaped gyros, each bearing four open, two-person gondolas. The gondolas are suspended at a horizontal rotation axis inclined to allow free sideways swings across both sides. The entire ride is on an incline, so the audience or bystanders have a clear view into the heart of the attraction and can follow the show ride cycle.

When the rotation of the main disc is activated, the gyros will perform a counter-rotation. The combination of the main disc slope, gyro movement and weight displacement within the suspended gondolas create a cycloid trajectory, causing them to swing sideways. The oblique mount and the motion of the ride will lead the gondolas to perform unpredictable 360° side flips, building up to multiple loopings at high speed.

The new ride can also reverse direction. Through different ride programs, the Booster Revolution offers both, a controlled show ride with a huge number of staged movements, as well as countless free ride patterns based on pure physics.

## PROFILE

- **Innovative design – mighty machine – that’s HUSS®!**
- **Two rides in one attraction** – exciting adventure and extreme thrill
- **Two-lane queue system** – optimized operation & guest flow
- **High capacity** – enormous guest appeal
- **Maximized performance** – more powerful than ever before
- **Show ride** with complete & interactive show control

## OPTIONS

- **HUSS® Design** – individual theming & illumination concept
- **Customized show ride cycle** following an individual soundtrack
- **Multimedia package**
- **Special effects**



## Technical Data

Footprint	19.4 m Ø (excl. platform)
Height	5.8 m (excl. centre decoration)
Number of Gondolas	20
Total Number of Passengers	40
Allowable Passenger Size	from 1.37 m to 1.95 m
Theoretical Maximum Capacity	1200 pph
Ride Programs	min. 3
Installed Power at Drive Unit	135 kW
Restraint	over the shoulder lap bar



## GONDOLA

- Brand new design with more space & comfort
- Individual lap bar per seat for additional safety
- On-board sound system & multimedia
- Extensive illumination

## CENTRE

- HUSS® Operator Centre Stage
- Operator part of the ride – part of the show
- Interactive show control
- 360° Overview



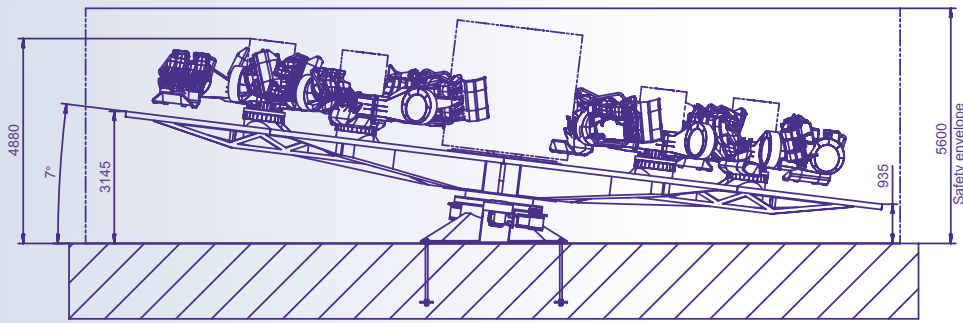

Gyro Decoration  
Design Space

Center Decoration  
Design Space

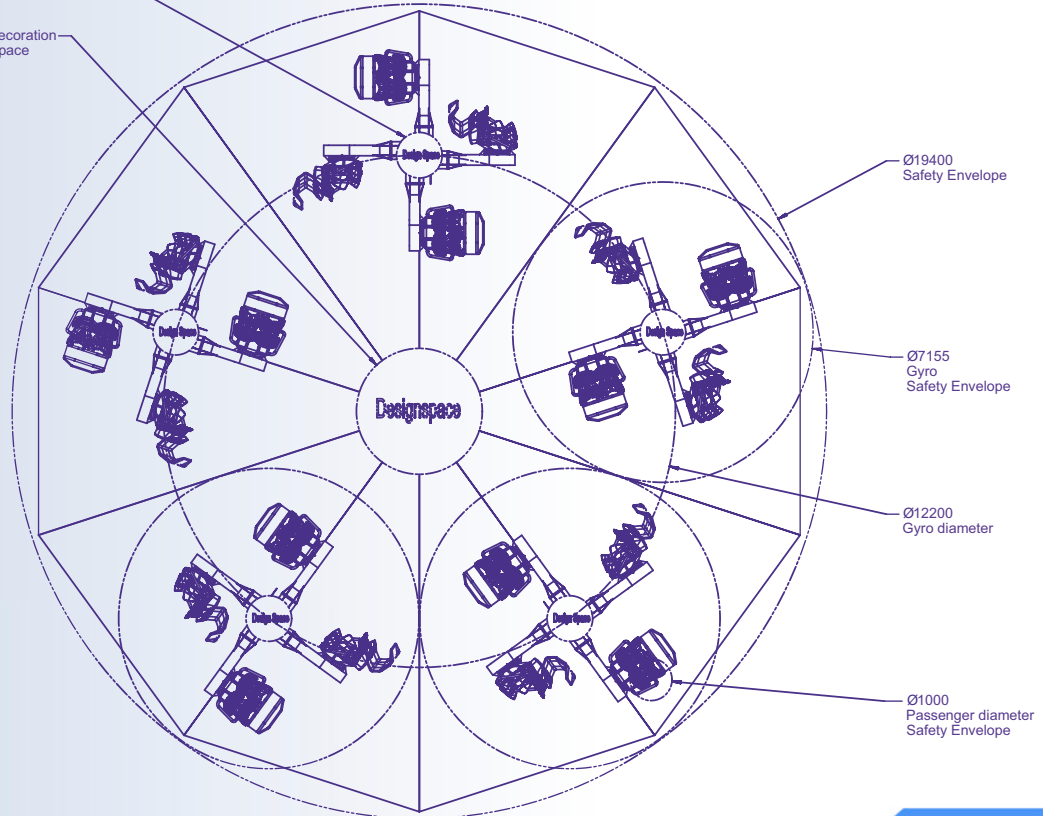

**Head Office:**  
**Huss Park Attractions GmbH**  
 Emil-Sommer-Str. 4-6  
 28329 Bremen, Germany  
 Tel +49 421 49900 0  
 sales@hussrides.com

**After Sales Service:**  
**Huss Parts & Service GmbH**  
 Emil-Sommer-Str. 4-6  
 28329 Bremen, Germany  
 Tel +49 421 49900 30  
 service@hussparts.com

